

# ella

## FIXED SUPPORT ARM

GLA600-W  
GLA900L-W  
*user manual*

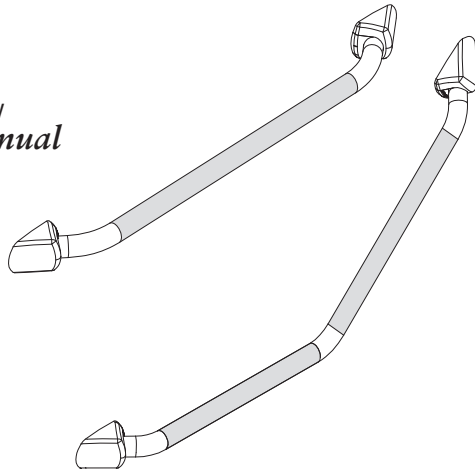

### INTRODUCTION

Thank you for purchasing an authentic Pearl® product. The ELLA line of home care products combines function, safety and style for reliable in-home security and superior comfort. Each and every unit was tested and carefully inspected by hand before delivering to our retailers.

Please read the instructions carefully to prevent any malfunction, property damage or injury.

### INCLUDED SCREWS



**Standard screws and fishers are included. Suitable for solid brick walls and concrete walls ONLY.**

For other walls use appropriate screws and fishers to avoid property damage and/or injury.

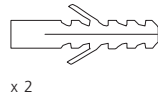
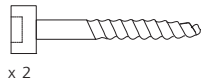

There are many different types of wall materials and fixing kits. Check with your local specialist hardware store or a qualified professional to ensure you are using the correct components. We strongly recommend that installation be performed by a licensed professional.

### WARNINGS AND INSTRUCTIONS



**An incorrectly installed product can cause serious injury or damage.**

ELLA home care products must be strongly secured to the wall. Ensure that your bathroom walls are strong enough to bear 150kg (330 lbs).

*We strongly recommend that installation is performed by a qualified professional, e.g. a licensed plumber.*

PEARL® cannot be held liable for injury to persons or damage to property caused by faulty mounting.

### INSTALLATION SPECIFICATIONS

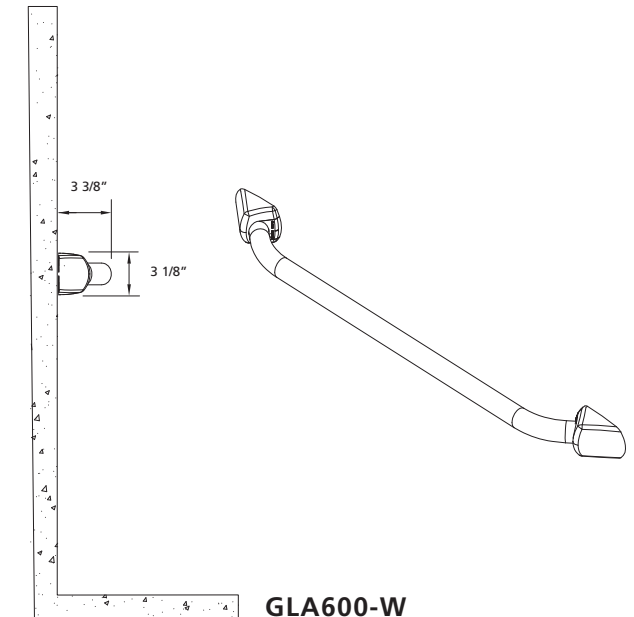
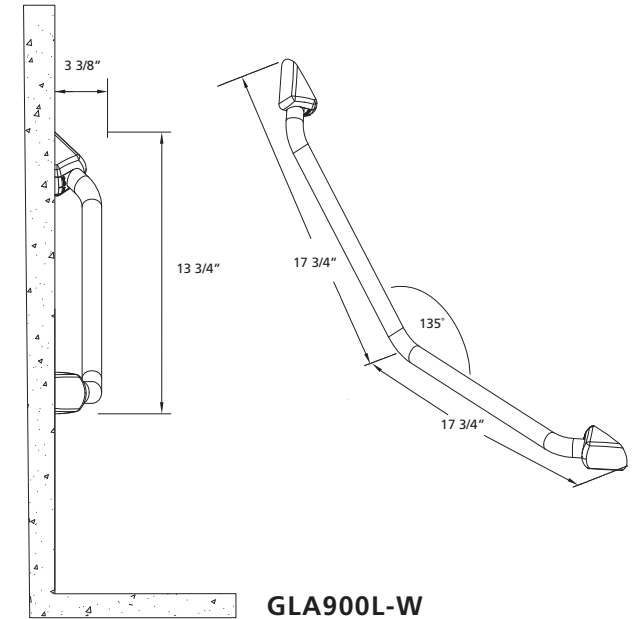

## INSTALLATION

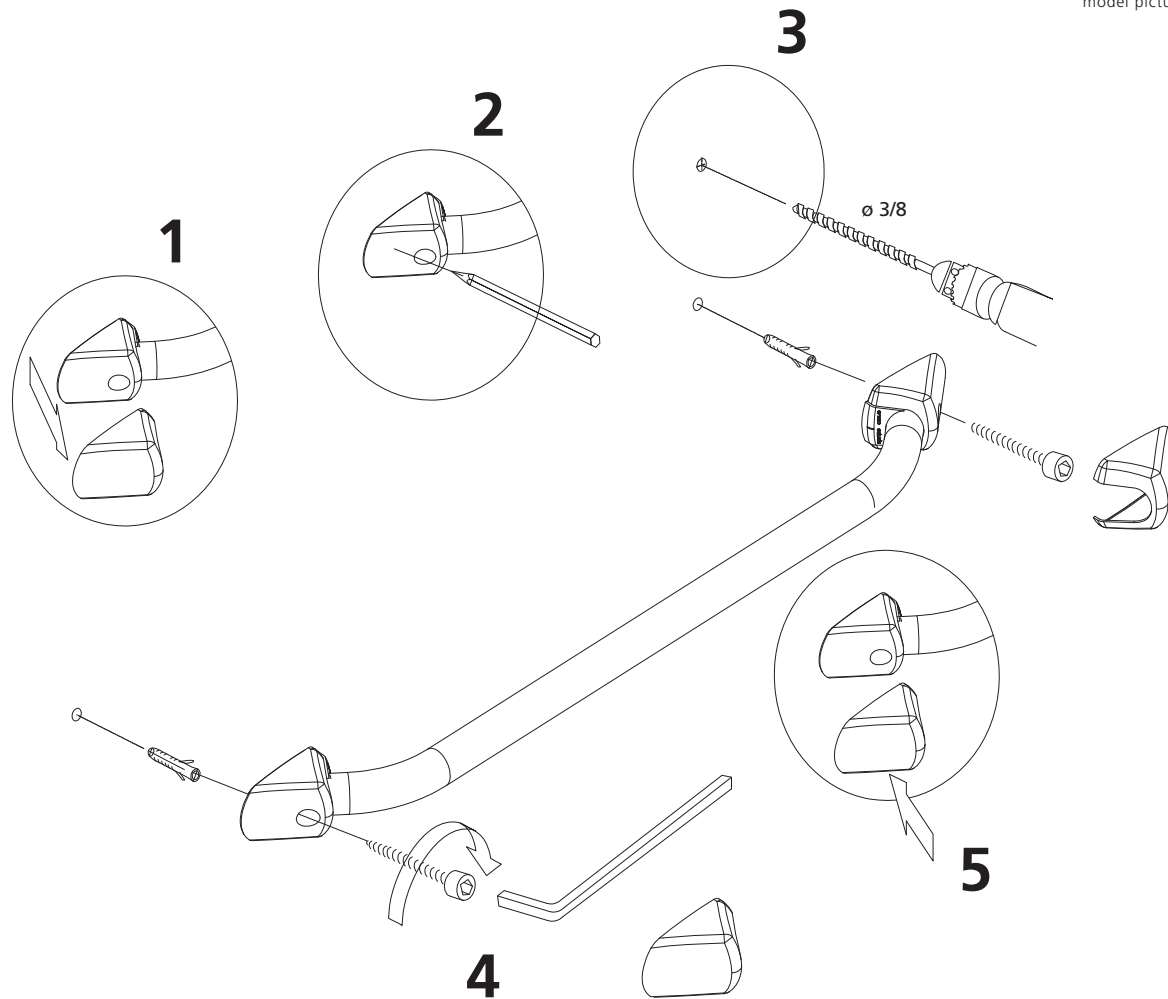

model pictured : GLA600-W

## WARRANTY

PEARL® offers a Limited (1) Year Warranty for its ELLA home care products. This warranty covers manufacturing defects in material and workmanship of PEARL® ELLA support arms, seats, and bars (Hereinafter referred to as the "Product") only.

Warranty starts from the invoice date of the Products. Any returned materials must be accompanied by a return requisition form and number from PEARL® RMA requisition department.

Proof of purchase may be required in order to be valid for warranty benefits. (Commercial applications are not applicable to any warranty below).

Exclusive Remedy: In the event of any defect in the Product that breaches the foregoing warranties, PEARL®, at its option, will repair or replace the defective part of the Product. PEARL® is to be notified describing the problem to claim the defective product. To notify PEARL® and receive assistance or service under this warranty, the original purchaser may: (1) call 1-604-242-1601 where a consumer service representative will be able to assist you, or (2) write the consumer service department c/o PEARL®, Unit 120, 1231 Burdette Street, Richmond BC, V6V 2Z2, and include a description of the problem, model number, location of purchase, your name, address, phone number and approximate date of purchase, or (3) email PEARL® customer service department by going to [www.pearlsinks.com/contact-us](http://www.pearlsinks.com/contact-us), or (4) notify the location or distributor from which the Product was purchased. You may be required to return the Product to PEARL® for inspection and proof of purchase may be required.

Limitations and Exclusions: PEARL® WILL NOT BE LIABLE FOR ANY OTHER DAMAGES OR LOSSES, INCLUDING, BUT NOT LIMITED TO, INCIDENTAL AND/OR CONSEQUENTIAL DAMAGES, REGARDLESS OF THE LEGAL THEORY ASSERTED, INCLUDING ANY CLAIM OR BREACH OF WARRANTY HEREUNDER OR ANY OTHER CAUSE, AND WHETHER ARISING IN CONTRACT OR IN TORT (including negligence and strict liability).

The above warranties do not cover any labour, natural wear and tear due to regular use to the surface finishing of the product, damage resulting from improper maintenance, repair, cleaning or installation, misuse, abuse, alterations, accidents, natural deposits, natural oxidation and erosion, or acts of God. Damage to the product caused by accident, misuse or abuse is not covered by this warranty. Failure to comply with cleaning instructions may void this PEARL® Warranty. PEARL® will not cover other costs associated with reinstallation or replacement of the product or its accessories.

If any malfunctions occur or if installation assistance is needed, please contact PEARL® Consumer Service at [www.pearlsinks.com](http://www.pearlsinks.com), you can also email us at [info@pearlsinks.com](mailto:info@pearlsinks.com) or call us at 1-604-242-1601.

\*Labour, shipping and handling not included

## MAINTENANCE

Simply rinse the surface of the product with clear warm water and soap.



Do NOT use any acidic cleaning solutions, abrasive cleaners, or harsh cleaners, as it may damage the product's finish.



[lifewithpearl.com](http://lifewithpearl.com)