

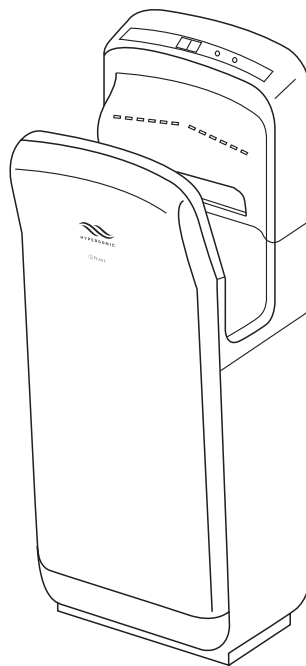

HYPERSONIC

AUTOMATIC HAND DRYER



GCA206XL
USER MANUAL

LIFEWITHPEARL.COM

Do not attempt to install the unit yourself unless you are a trained service technician, as it may affect the safety and proper functioning of the unit.
 Read this manual thoroughly before beginning to use this unit to ensure proper setup and safe usage. Please keep the manual for future reference.

CONTENTS

CONTENTS, FEATURES, SPECIFICATIONS	1
WARNING	2
PART NAMES, DIMENSIONS	3
USAGE	4
ROUTINE CLEANING	5
TROUBLESHOOTING, ELECTRICAL SCHEMATIC	6
PRECAUTIONS BEFORE INSTALLATION	7
INSTALLATION	8
TEST RUN	9
PACKING LIST	10

CHASE DRYER FEATURES

- No touch hand drying increases hygiene
- Eliminates need for wasteful paper towels
- Saves electricity by drying hands at high speed
- Easy to maintain
- Anti-bacterial surface
- Elegant stainless steel shell
- Anti-damage timer
- Automatic heating system

The anti-damage timer shuts off the machine after working 25 seconds. Remove your hands and reinsert to continue use.

NO WINDPIPE

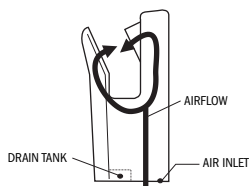

- Separate air supply increases hygiene and doesn't allow water to drip into unit

HIGH AND LOW SENSORS

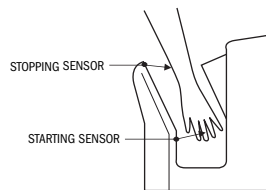

- Prevents water from splattering the body

ENGINEERED FOR HUMANS



- Easy and comfortable to use

SPECIFICATIONS

VOLTAGE: AC120V
INPUT: 1700W
MOTOR: BRUSHLESS DC

WIND VELOCITY: 342 kph (212 mph)
HEATING POWER: 1000-1200W
INDUCTION METHOD: IR BLOCKING

DIMMENSIONS: 300X220X685mm
NET WEIGHT: 10.5kg
PROTECTION CLASS: IPX4



WARNING Failure to follow instructions may lead to serious property damage and personal injury



Prohibited



Do not allow unit to get wet



Do not use in bathtub or shower stall



Disassembling prohibited



Ground



- Do not open the front panel. There is the risk of electrocution.
- Do not let children hang from the unit, this may cause the unit to fall.
- Do not let the unit get wet, it can cause electric shocks.
- Do not use in a wet environment, where it may come into direct contact with water or where condensation may form. This may cause electric shocks or unit malfunction.
- Do not modify or disassemble the unit unnecessarily. This may cause electric shock, fire, or personal injury.
- Rated power is required.
- If power tolerance is over +/- 10%, there will be breakdown. Incorrect power supply usage will lead to fire, electric shock, and/or machine malfunction.
- Use dedicated socket.
- If using with other appliances, the socket may produce abnormal heat leading to fire.
- Power must be cut off during maintenance to eliminate the risk of electric shock.
- Drain tank and air filter must be installed.
Do not switch on until after the power has been connected for 10 seconds.
- If the machine doesn't work or is behaving abnormally, cut off power, close leakage circuit breaker and ask supplier to check and repair.
- ▲ Machine must have reliable ground connection.
- ▲ Do not install when the machine is connected to a power source. Unit must be installed by a professional tradesperson.
- This appliance is not intended for use by persons (including children) with reduced physical, sensory or mental capabilities, or lack of experience and knowledge, unless they are supervised and/or have been instructed on the proper use of the machine from a person responsible for their safety.
- If the cord is damaged, it must be replaced by the manufacturer, service agent or similarly qualified person in order to avoid a hazard.
- For additional protection, the installation of a residual current device(RCD) having a rates residual operating current not exceeding 30mA is advisable in the electric circuit supplying the bathroom. Ask you installer for advice.
- **Environmental Protection**
Electrical waste products should not be disposed of with household waste. Please recycle where facilities exist. Check with your Local Authority or retailer for recycling advice.

PART NAMES AND DIMENSION DRAWING

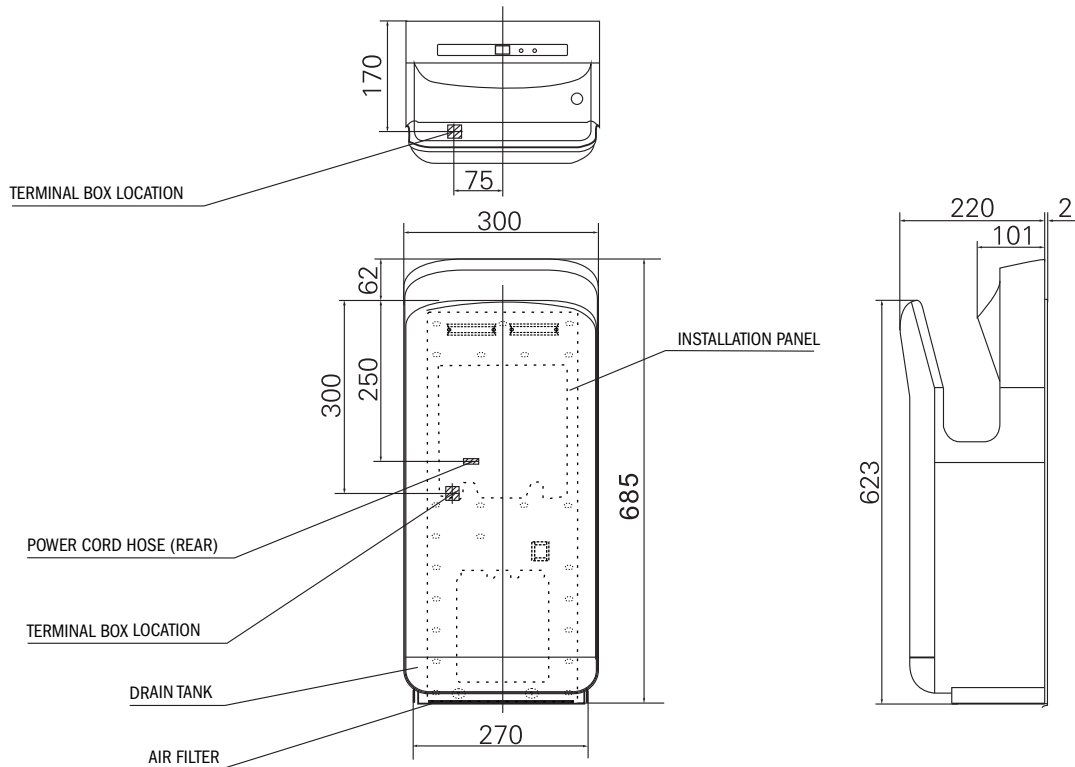
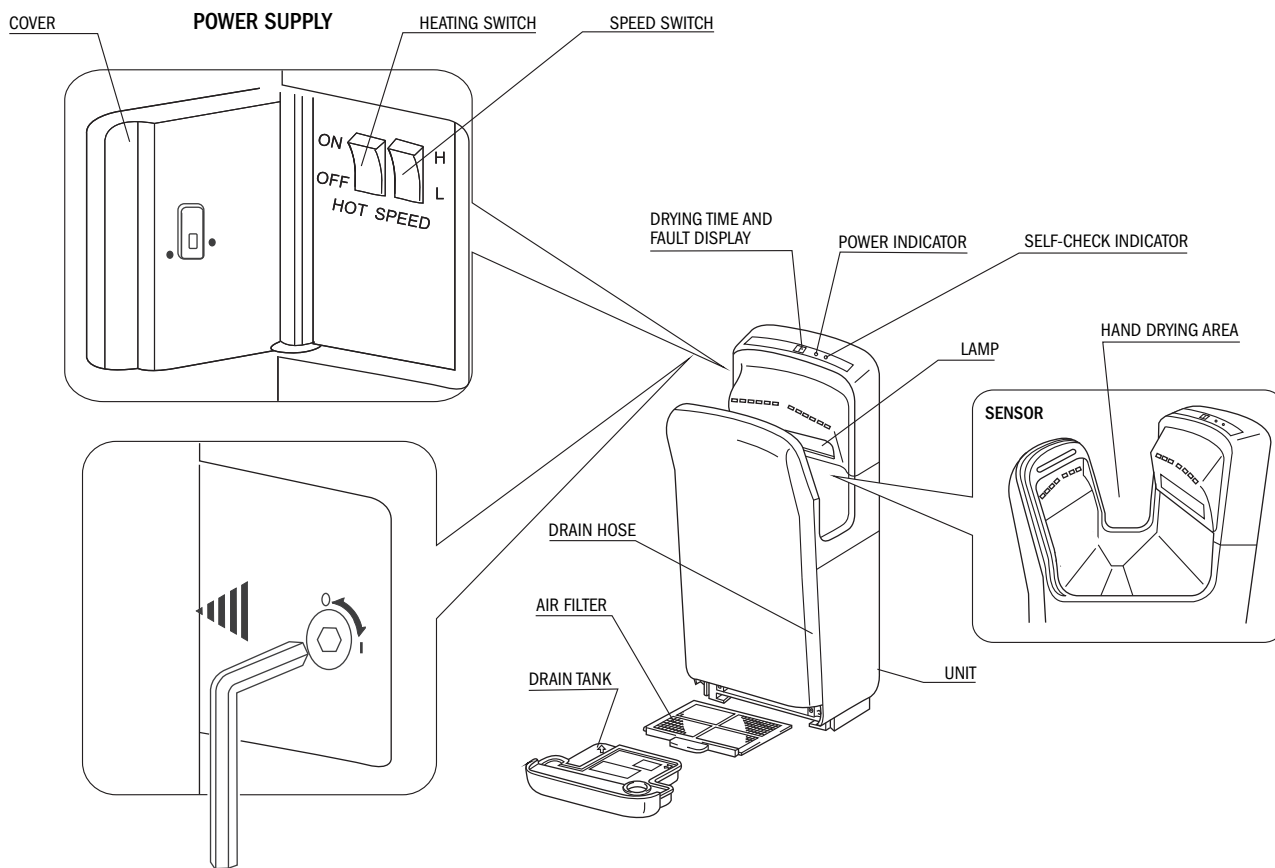

USING THE UNIT



- Insert both hands into the hand drying area. The unit will start to run automatically.

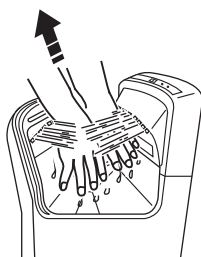

- Pull hands out slowly, allowing the air to dry hands.



- Remove hands once dry.

SELF-CHECK INDICATOR

When a malfunction occurs, the self-check indicator on the right side will either light up or flash. Turn off power switch, wait about 40 seconds until all the indicators go off, then turn on the power switch. If the indicator still lights up or flashes, turn off the power, disconnect the unit from the socket, and contact your dealer immediately.

USAGE LABEL



Attach the usage label in a visible location (The front of the unit or on a nearby wall).

NOTE: When turning on the unit, flip the power switch and make sure:

- The power indicator lights up
- The lamp lights up
- The cover of the power supply is closed

ROUTINE CLEANING

NOTE



- Only use neutral cleaning agents.
- Do not use thinner, acidic or alkaline cleaners, or nylon brushes (they may cause damage to the surface).
- Do not use any alcohol to clean the machine.
- Disinfecting agents will damage your unit.
- Read the labels of cleaning products to see if they are safe for use.

CLEANING THE UNIT BODY

Before it gets obviously dirty

Clean the unit with a soft cloth.

If the unit gets very dirty, clean with a soft cloth dampened with neutral cleaning agent, then clean with a soft dry cloth. Remove the dirt from the sensor (to prevent malfunction).

DRAINING AND CLEANING THE DRAIN TANK

At least once a week

The water blown off the hands is called “drain water”. Empty the drain water regularly in order to prevent overflow. The drain water will start smelling if it remains in the tank for too long.

1

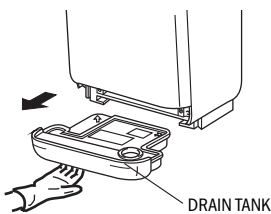

- Pull the drain tank out horizontally. This ensures the drain water does not splatter out.

2

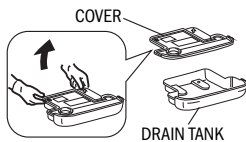

- Open the cover and empty the water.

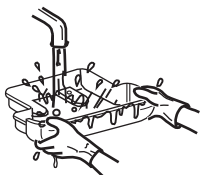

- Wash out the interior of the drain tank.



- Close the water tank cover, and re-attach it to the unit.

3

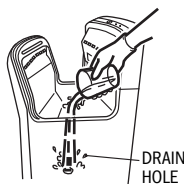

- Add 1 cup of water through the drain hole to prevent clogging.
- Test the unit after confirming the tank is back in its place.



WARNING

- Before you clean the unit, turn off the power switch.
- Do not splatter water on the unit



CAUTION

- Wear gloves when cleaning

NOTE



- The antibacterial coating is effective when bacteria are exposed to the coated surfaces. The coating is ineffective when the surfaces are very dirty.

CLEANING THE AIR FILTER

Around once a week

1

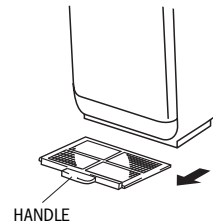

- Pull the air filter out by the handle.

2



- Clean the filter by tapping lightly by hand or using a vacuum cleaner. If it is very dirty, wash it with cold or warm water. Let air dry.

3

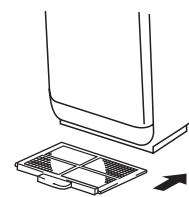

- Slide the filter back into the unit, making sure that it goes all the way in. (If it is not in place, dirt or dust will enter the unit and shorten its service life).

NOTE



- If you wash the filter with water, be sure to dry it as much as possible
- Do not expose to fire or intense heat

TROUBLE SHOOTING, ELECTRICAL SCHEMATIC

TROUBLESHOOTING TABLE

PROBLEM	CHECK	ACTION
No air flows even if hands are in sensor area	Do the display indicators light up? Is the power switch on? Are the hands fully inserted?	Turn the ground-fault circuit breaker on. Turn the power switch on. Put hands all the way in.
Machine continues to work long after hands are drawn out, then finally shows E2	Is there any dirt or foreign body on the sensor?	Switch off the power button, and then remove any dirt or foreign body on the sensor after the light has gone out. Turn power back on.
The air blown is not hot	Is there any dirt on the sensor? Is the internal heating fuse burned? Is the ambient temperature higher than than 25 °C?	Clean off dirt (see #2 above). Turn off power switch. Remove the front panel and you will see a fuse holder (see fig.5 pg9). Unscrew the fuse holder and replace burnt fuse. The heater does not turn on above 25 °C for the comfort of the users.
Airflow is too low	Is the speed button set to low?	Set speed to the high level.

If the above actions do not solve the problem, turn off the power and ground-fault circuit breaker, and call your dealer to inspect and repair if necessary (costs are per agreement with the dealer).

ELECTRICAL SCHEMATIC

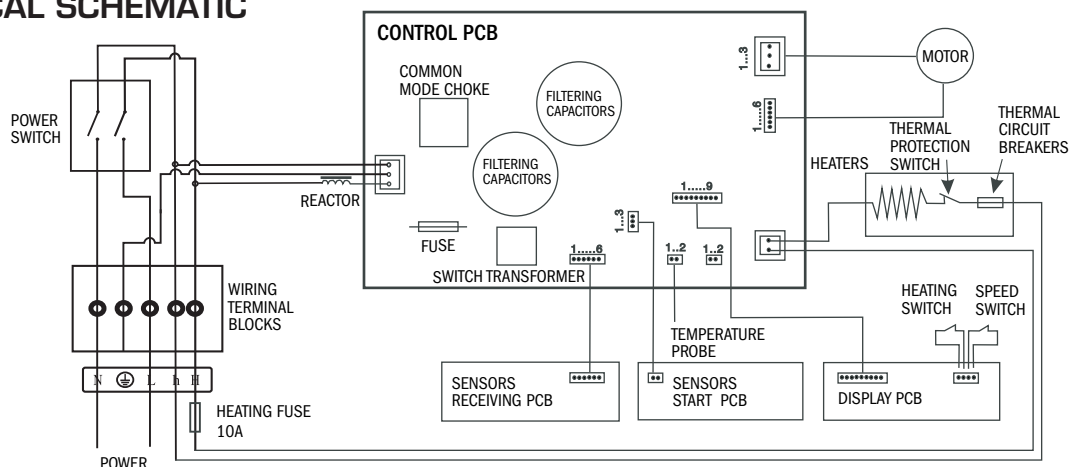

	Status	Introductions	Status	Introductions	Solution
Power indicator light	Lit	Power input normally	Extinguished	No power supply	Check the external power source, close the power switch
				Master board fuse blew out	
State indicator light	Extinguished	Doesn't work	Flashing light	Motor fault, it can't start normally	Check motor connecting wires and the rotor for foreign materials
	Always on	Working		Trick or working time longer than 25s	Clear workspace of foreign materials, restart to work
Timing digital tube	Digital changes	Countdown work	Jump display $\square\square$	Indicate drying time is finished	
	E1	Motor fault, it can't start normally	E2	Trick or working time longer than 25s	Clear workspace of foreign materials, restart to work
	E3	The voltage exceeds 15%	E4	Voltage is lower than 15%	Check the power supply circuit
	E5	Machine temperature is higher than 80°C	E6	Master board temperatures higher than 80°C	Clear the foreign material from the air inlet and air outlet
			E8	Fan Fault	Check whether the fan sensor connection is loose

PRECAUTIONS BEFORE INSTALLING

TO AVOID MALFUNCTION, DO NOT INSTALL IN THE FOLLOWING PLACES:

- Where the temperature is less than -10°C or over 40°C
- Where the unit may come into direct contact with water
- Where the unit is under direct or strong sunlight
- Where corrosive or reductive gases are present
- Places lower than -20m or higher than 2000m above sea level

INSTALLATION LOCATION:

- Install at a location where the unit will be easy to use, as shown in the figure
- The bottom of the unit must be at least 150mm higher than the floor or any objects under it
- If the unit is installed too low, water may get on it when the floor is being cleaned
- The left side of the unit must be at least 150mm away from any walls because the power switch is located on the left
- Ensure there are no mirrors or walls near the right side, as water may splatter to the right when drying hands (recommended distance at least 100mm)
- Avoid locations where people or doors might bump into the unit
- Choose a completely flat surface to install the unit

INSTALLATION BASE:

- If your space is limited and the condition of your wall is unsatisfactory, you can purchase an installation base to install this unit.

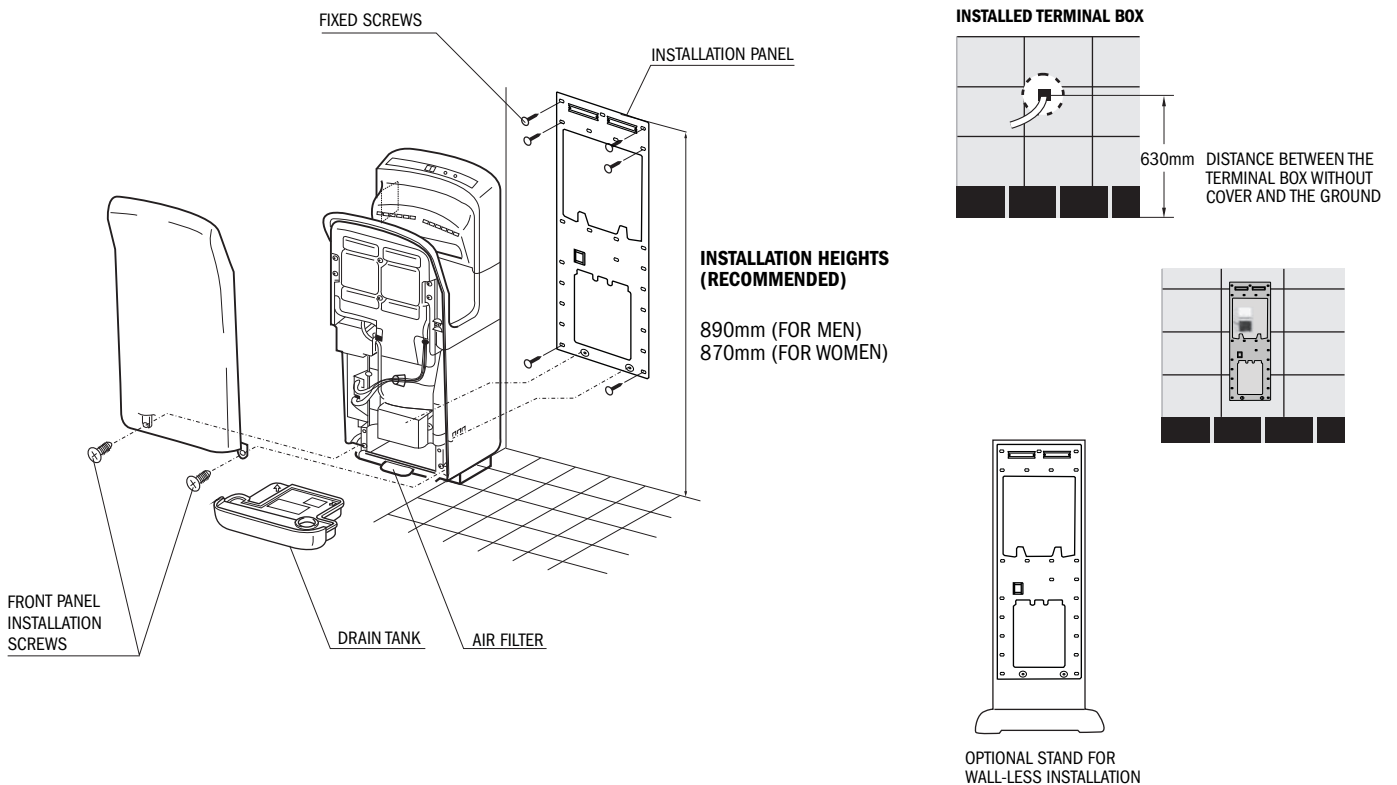

- **Use a single-phase alternating rated voltage supply (Not to used with a power supply exceeding rated voltage $\pm 10\%$)**

Only use a power cord which is between 2mm² and 2.5mm² thick.

(A drop in voltage is possible if the power cord exceeds 11m in length, so we recommend using a 2.5mm² cord)

1

Wire the unit

Embed the switchbox in the installation location (1 switchbox no cover) and wire the power cord (the green and yellow combined is the ground line)

If no switchbox is used, the power cord will be pushed out and prevent the unit from being installed firmly against the wall.

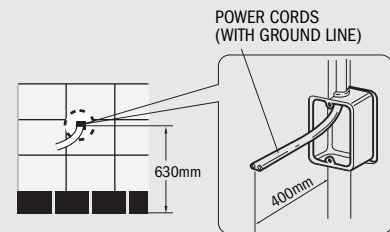

2

Attach the installation panel to the wall using the 6 installation screws

If the wall is concrete, use commercially available metal screw plugs (curl plugs etc.)

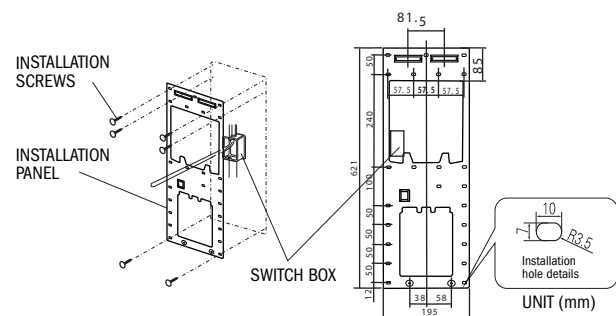

3

1. Remove the drain tank

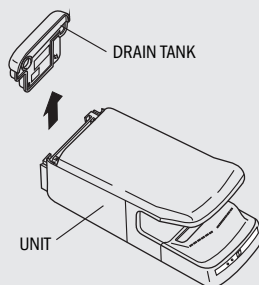

2. Remove the front panel

- (A) Remove the two screws
(B) Remove the 3 front panel chuckholes

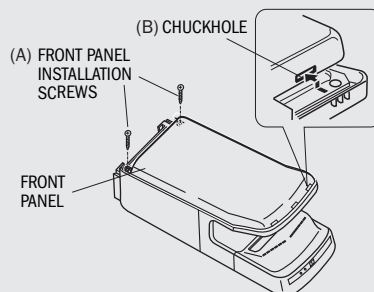

3. Remove the terminal box cover

Remove the terminal box cover screw and pull the cover out towards you.

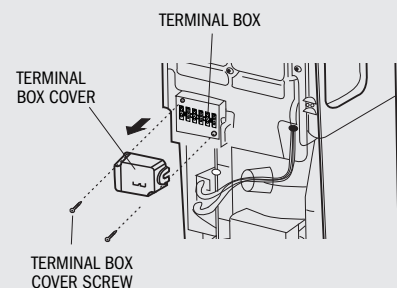

4

Pull the power cord into the unit and secure inside

Pull the power cord through the power cord hole on the rear of the unit.

Attach the rear of the unit to the 2 hooks on the installation panel.

The installation screws for the unit will not tighten completely if the hooks at the bottom of the installation panel are not in place.



Ensure the unit is hooked on the installation panel, and that the safety screws (at the bottom right) are tightened. Otherwise the unit may drop or be in danger of theft.

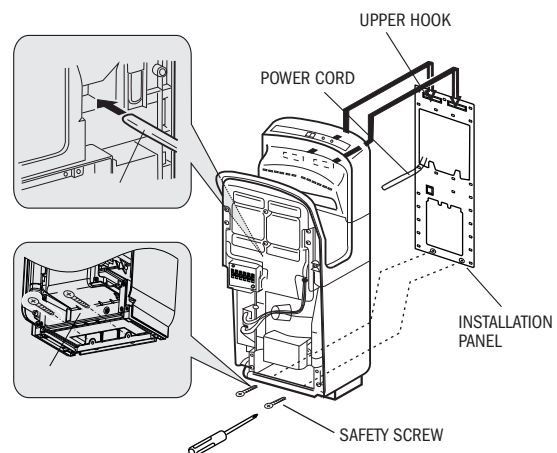

INSTALLATION PROCEDURES

5

Wire the terminal box

- 1) Strip the wire sheath as shown in the figure on the right
- 2) Loosen the screws on the terminal box and the power cord to the terminal box.
- 3) Remove the protective seal attached to the terminal box before connecting the ground wire.
- 4) Tighten the screws on the terminal box and pull the power cord to make sure it is secured firmly.
- 5) Bind the powercord using the clip to the right of the terminal box and fix it to its original location.

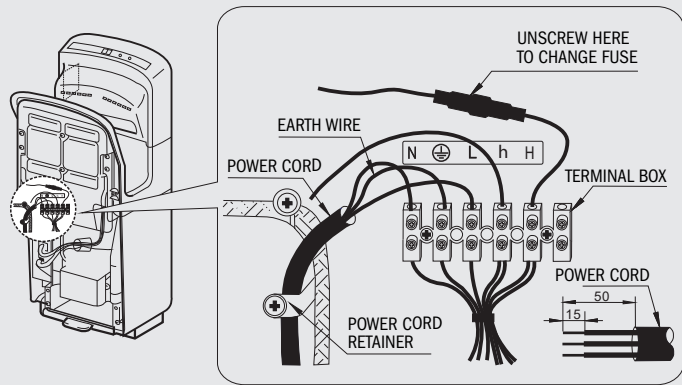

6

Attach the terminal box cover

- 1) Place the internal box tabs into the holes and return the cover to its original position, securing it with the screws.
- 2) Make sure the power cord and other wires are not pinched.

The front panel cannot be attached if there are any wires in front of the terminal box cover. Move the wires to the right of the terminal box cover.

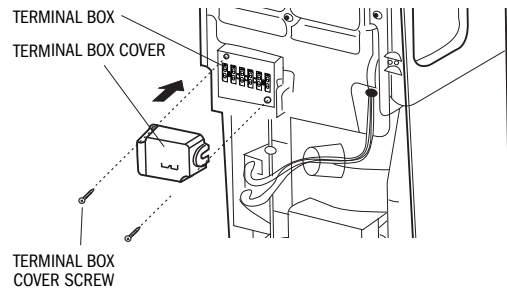

7

Attach the front panel

- 1) Insert the 3 front panel chuckholes into the unit.
- 2) Replace the 2 screws that were removed.

- 3) **Attach the drain tank.**
- 4) **Make sure the air filter is all the way in.**

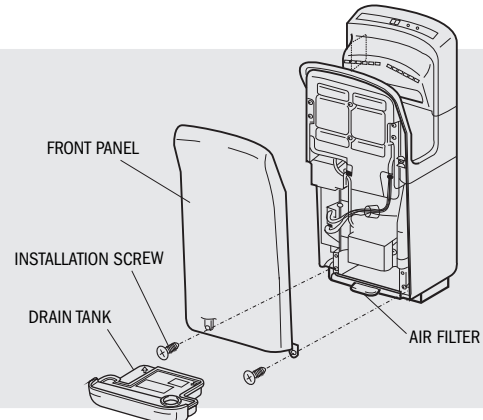

WARNING

Do not turn the unit power switch on with your hands inside. If the self-check indicator display light is flashing, turn off the power switch, and turn the power back on when all indicators turn off (after 40 seconds)

TEST RUN

STEP	CHECK
1 Check the power supply voltage	Make sure it matches the rated voltage
2 Turn the ground-fault circuit breaker on	
3 Turn the power switch on	Does the power indicator light up?
4 Insert hands into sensor area	Is the air blowing?
5 Check the unit	Is it installed firmly? Any vibrations or strange noises?

PACKING LIST

MAIN MACHINE (1)

MOUNTING PLATE(1)

5x25mm SELF TAPPING SCREW (6)

5mm EXPANSION PIPE (6)

USER MANUAL (1)

METHOD OF USE FIGURE (1)

ROUGHING EFFICIENCY AIR FILTER (1)

KEY (1)

HEPA (1)

Pearl® Inc. 120-1231 Burdette Street
Richmond BC Canada, V6V 2Z2

LIFEWITHPEARL.COM

